

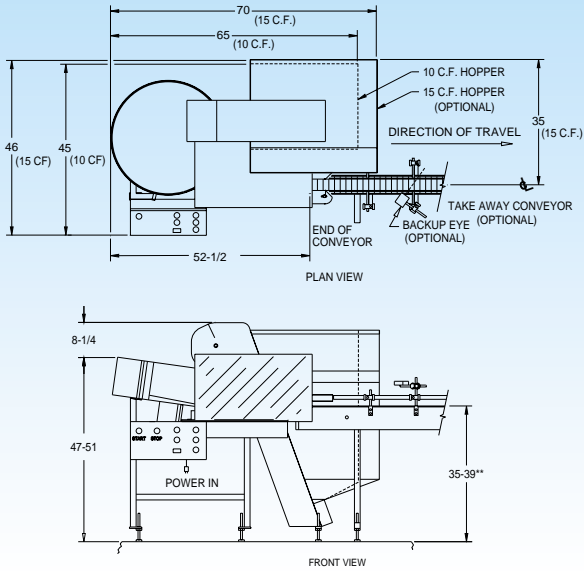

# ORIENTAINER® UNSCRAMBLERS AND ORIENTERS FOR BOTTLES AND JARS

## MICRO-MINI COMPACT BOTTLE UNSCRAMBLER Models AU-3 and AU-3M



## BOTTLE UNSCRAMBLER/CLEANER Models AU-5 and AU-5C

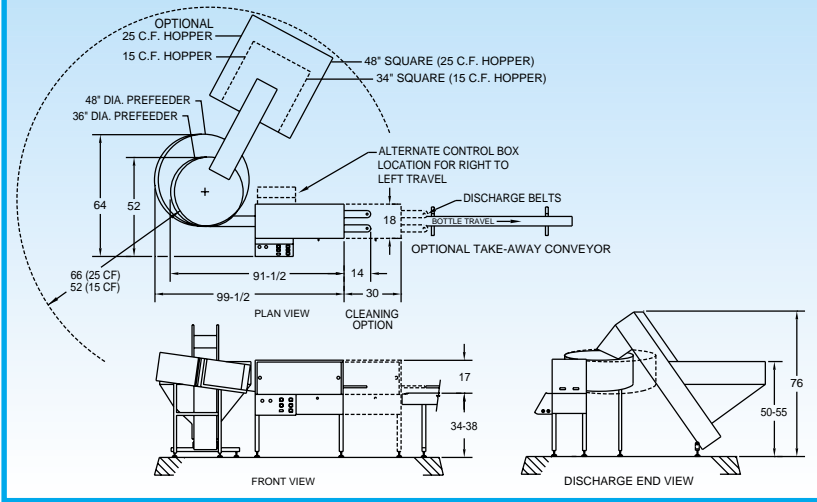

## COMPACT BOTTLE UNSCRAMBLER/CLEANER Models AU-6 and AU-6C

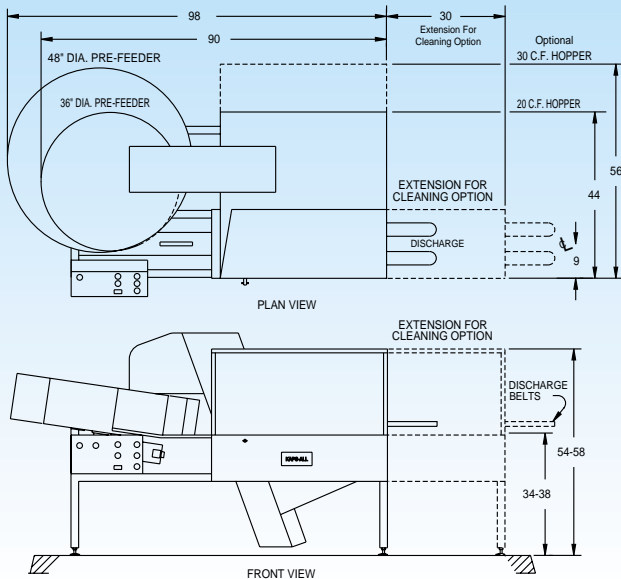

## SECONDARY BOTTLE ORIENTER Model SBO

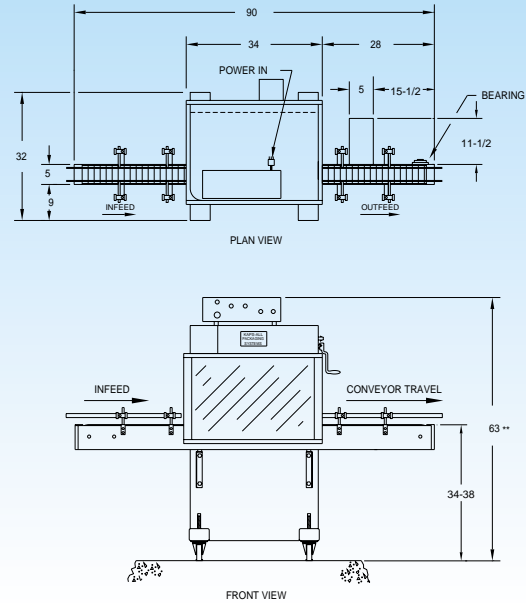

### Notes:

- 1) All dimensions shown are in inches. To convert to centimeters multiply inches by 2.54
  - 2) \* Indicates height based on a 34" high conveyor and a 6" tall container.
  - 3) \*\* Other conveyor heights available.
  - 4) Some items shown may be optional.
  - 5) Due to Kaps-All's commitment to maintain quality leadership in the packaging industry, dimensions, specifications and options subject to change without notice.
  - 6) Electrics: 110V, 1 PH, 60/50 Hz (standard) other voltages available on request.
- Air consumption: Approximately 2-4 CFM of air for AU-5C, and AU-6C with bottle cleaners only.

Represented By:

KAPS-ALL PACKAGING SYSTEMS, INC., 200 Mill Road, Riverhead, NY 11901-3125 USA Tel: (631) 727-0300 • Fax: (631) 369-5939 • [www.kapsall.com](http://www.kapsall.com)  
Developers and Manufacturers of Complete Bottling and Packaging Systems

- KAPS-ALL® Bottle Cappers and Cap Tighteners • FILLS-ALL® Automatic and Semi-Automatic Liquid Fillers • FEED SYSTEMS® Rotary and Escalator Parts Feeders • CLEAN-N-VAC® Bottle Cleaners
- ORIENTAINER® Bottle Orienters and Unscramblers • CONVEYS-ALL® Conveying Systems • EASY-KAP® Hand Cappers • Ball Placers • Bulk Loaders • Accumulators • Bottle Carriers • Desiccant Inserters
- Electronic Torque Metering and Monitoring • Heat Induction Bottle Sealers • Inspection Systems • Custom Packaging Machinery